

---

## FILLING AND CLOSING WITH ROTARY MACHINES Z-110

## FLEXIBILITY

Zellwag Pharmtech AG develops and builds filling and closing machines for the pharmaceutical, healthcare and cosmetics industry in the medium performance segment. The filling of different container formats on the same machine is our specialty. Our systems have a modular and compact design.

### Features

- Closure infeed via vibrating bowl
- Various infeed alternatives possible
- Servomotoric pre- and post-screwing axis with snap-on function, 3-jaw gripper closure holding
- Optional vacuum based container holding instead of clamping
- In process control: torque, rotation angle and position control by the screwing axes, closure position cross control with sensors
- Automatic outfeed of non-conform containers
- Tool-free format part change

### Customer benefits

- Fully automatic process run in compact monobloc design
- Easy to clean
- Modular closure infeed options for a variety of closure types
- Snap-on, screw-on and crimp-on closures on the same machine
- No scratching of sensitive containers
- Pre- and postscrewing unit for an increased and optimal output
- Easy and fast format change
- All electric parameters are saved within recipes
- All mechanical setting values are reproducible
- Expandable system

## FOOD SUPPLEMENTS

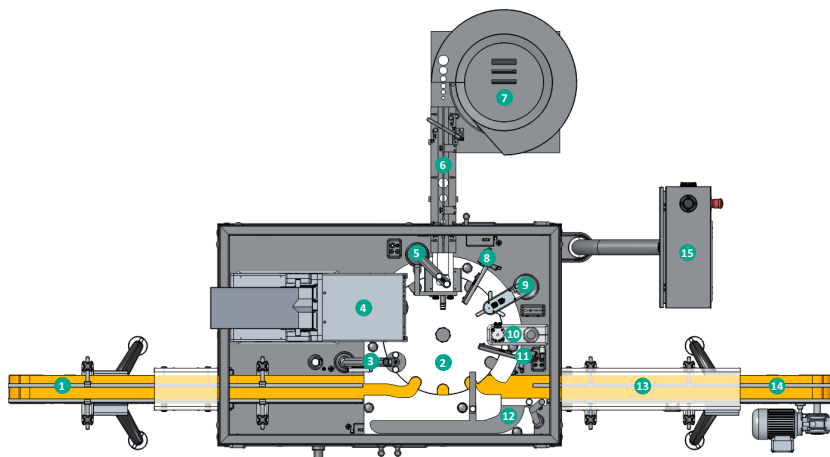

- 1 Container infeed
- 2 Star wheel
- 3 Blow out station
- 4 Counting system Multicount 60
- 5 Closure place station
- 6 Closure infeed
- 7 Vibrating bowl closures
- 8 Presence control closures
- 9 Screw-on station
- 10 Press-on station
- 11 Position control closures
- 12 NIO-area
- 13 Safety housing container infeed
- 14 Container outfeed
- 15 Operating panel HMI

# PHARMA

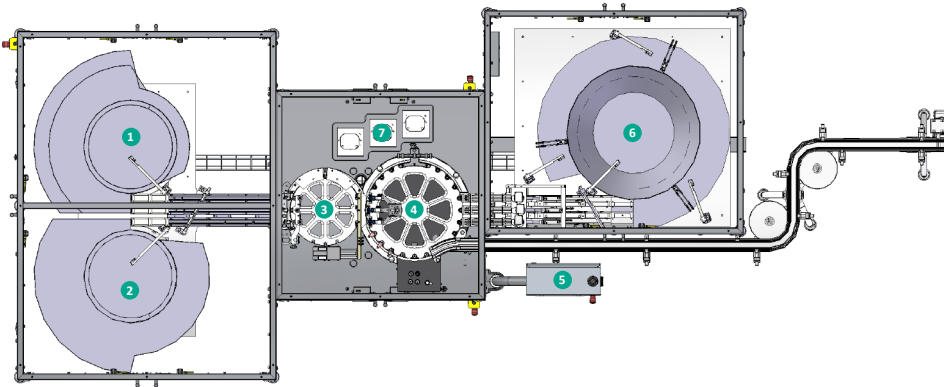

- 1 Vibrating bowl for pump spray heads
- 2 Vibrating bowl for pump spray heads
- 3 Turntable for pump spray heads
- 4 Turntable for bottles
- 5 Operating panel
- 6 Vibrating bowl for bottles
- 7 Pumps

# DIAGNOSTICS

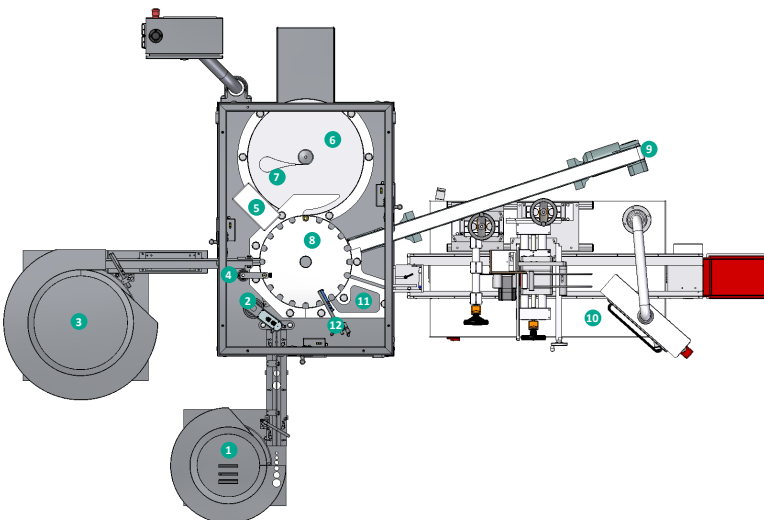

- 1 Infeed for caps / stoppers
- 2 Screw-on unit for caps
- 3 Infeed for Sarstedt- and Calex-tubes
- 4 Filling station
- 5 Rotary piston pump
- 6 Turntable
- 7 Aligning loop for bottles
- 8 Star wheel
- 9 Conveyor belt
- 10 Labeller für Sarstedt- / Calex-tubes
- 11 NIO-box / -channel
- 12 Cap control

## COSMETICS

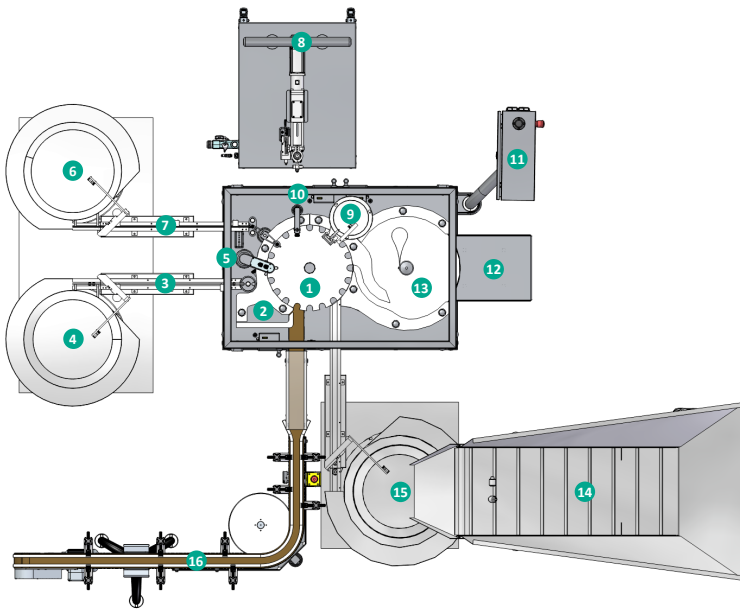

- 1 Star wheel
- 2 NIO area
- 3 Infeed conveyor caps
- 4 Vibrating bowl caps
- 5 Screw-on station
- 6 Vibrating bowl brushes
- 7 Infeed conveyor brushes
- 8 Pump station
- 9 Ball delivery system
- 10 Filling nozzle
- 11 Operating panel for HMI
- 12 Infeed glass bottles
- 13 Turntable glass bottles
- 14 Infeed bunker plastic bottles
- 15 Vibrating bowl plastic bottles
- 16 Outfeed conveyor

## COSMETICS WITH PUCKS

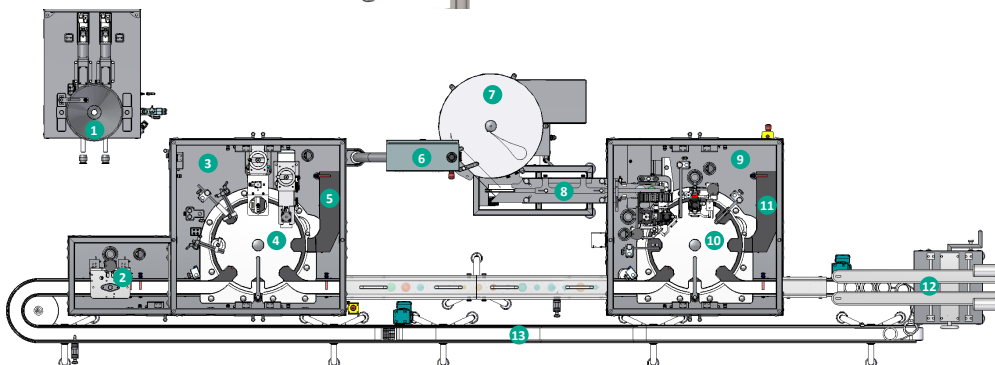

- 1 Pump station
- 2 Blow out and suction device
- 3 Machine part filling and sealing
- 4 Star wheel filling and sealing
- 5 NIO-area for filling and sealing
- 6 Operating panel for HMI
- 7 Turntable for caps
- 8 Infeed conveyor for caps
- 9 Machine part screw-on / press-on
- 10 Star wheel screw-on / press-on
- 11 NIO-area screw-on / press-on
- 12 Separation area puck / container
- 13 Circulating conveyor belt